

## Familial cerebral cavernous malformation

Tomasz Dzedzic<sup>1</sup>, Przemysław Kunert<sup>1</sup>, Ewa Matyja<sup>2,3</sup>, Karolina Ziora-Jakutowicz<sup>4</sup>, Antonella Sidoti<sup>5</sup>, Andrzej Marchel<sup>1</sup>

<sup>1</sup>Department of Neurosurgery, Medical University of Warsaw, <sup>2</sup>Department of Experimental and Clinical Neuropathology, Mossakowski Medical Research Centre, Polish Academy of Sciences, <sup>3</sup>Department of Neurosurgery, M. Skłodowska-Curie Memorial Cancer Centre and Institute of Oncology, <sup>4</sup>Institute of Psychiatry and Neurology, Warsaw, Poland, <sup>5</sup>Department of Biomorphology and Biotechnologies, University of Messina, Italy

*Folia Neuropathol* 2012; 50 (2): 152-158

### Abstract

*Cavernous malformations (CMs) occur in approximately 0.5% of the general population and represent 5-10% of the central nervous system vascular malformations. The majority of CMs appear sporadically but genetically determined familial forms account for 10% to 15% of all cases.*

*The aim of this study was to discuss the clinical, pathological and genetic aspects of familial cerebral cavernous malformations (CCMs). We report on five members of a family who underwent surgery due to CCMs. However, only two members were treated in our Department. The age of onset of symptoms in these cases (4 men and 1 woman) ranged from 3 to 28 years. Three members of the family were asymptomatic but it turned out that they were obligatory gene carriers and in one of them the cavernous malformation was confirmed by neuroimaging study.*

*The clinical symptoms of CCMs included seizure (three patients) and focal neurological deficit (two patients). Multiple CCMs were identified in two symptomatic patients (two lesions) and in one asymptomatic patient (three lesions). The lesions were located superficially (4), in the basal ganglia (1), in the brainstem (2) and in the cerebellar vermis (1). In two patients, the subsequent imaging studies showed a single de novo CCM formation. Only one patient with mutation of CCM2 gene was treated surgically.*

*In patients with cavernous malformations the detailed clinical and family history of neurological events ought to be collected. This is particularly important in patients with multiple changes or with de novo CCMs formation, identified in subsequent imaging studies. A well-documented family history can help to establish the final diagnosis and makes it possible to offer all members of the family proper neurological and genetic care.*

**Key words:** cavernoma, familial cavernous malformation, de novo formation, multiple, CCM, CCM2.

### Introduction

Cavernous malformations (CMs) are vascular malformations composed of a collection of abnormal, thin and dilated vascular channels, whose walls consist only of a single layer of endothelium lacking elastin and smooth muscles [14,19]. The feature that distinguishes

them from other types of vascular malformations is the absence of intervening brain parenchyma [9,14]. Cerebral cavernous malformations (CCMs) constitute about 10% of all vascular malformations [14,18]. They affect about 0.4-0.8% of the population as assessed on the basis of screening MRI findings and post-mortem studies [9,18]. CCMs may occur either as a spo-

### Communicating author:

Tomasz Dzedzic, Department of Neurosurgery, Medical University of Warsaw, e-mail: tomasz\_Dzedzic@wp.pl

radic or inherited autosomal-dominant form [12] due to the mutation of one of three genes located on the long arms of chromosomes 7 and 3 or on the short arm of chromosome 7 [11]. The mutation of these genes varies and is especially common in the Mexican-American population [18]. Patients with multiple lesions constitute 12-20% in sporadic form and more than 50% in the familial form of CCMs [9,18]. Cavernous malformation may present with a progressive focal neurological deficit and/or seizure, or may be diagnosed incidentally [7,9,14]. In MRI studies, CMs typically appear in T2-weighted images as “popcorn-like” masses. They consist of a mixed signal intensity core usually accompanied by a hypointense hemosiderin rim [14] (Fig. 2). These changes are rarely demonstrated on angiography and they are considered as angiographically occult vascular malformations [17]. Currently, the highly sensitive T2-weighted gradient-echo imaging is a gold standard MRI sequence in CCM diagnosis [3].

**Material and methods**

The presented data were collected from available medical records, family history and molecular genet-

ic testing. Five members of this family were operated on due to lesions with radiological appearance of cavernous malformation. The histopathological examination of biopsy specimens was documented in two cases. One member of the family was examined for molecular genetic testing.

**Results**

**Collected data from available medical records and family history**

Two members of the family were admitted to our Department of Neurosurgery due to identified cavernous malformation changes on MR imaging. Three members were treated surgically in another medical institution due to the cavernous malformation. One of the asymptomatic patients, who presented multiple changes with MRI features typical for cavernous malformation, was an obligatory carrier of the *CCM1* gene. In two other asymptomatic individuals, who were carriers of the same gene, the imaging test was not performed. The pedigree of this family is shown in Fig. 1.

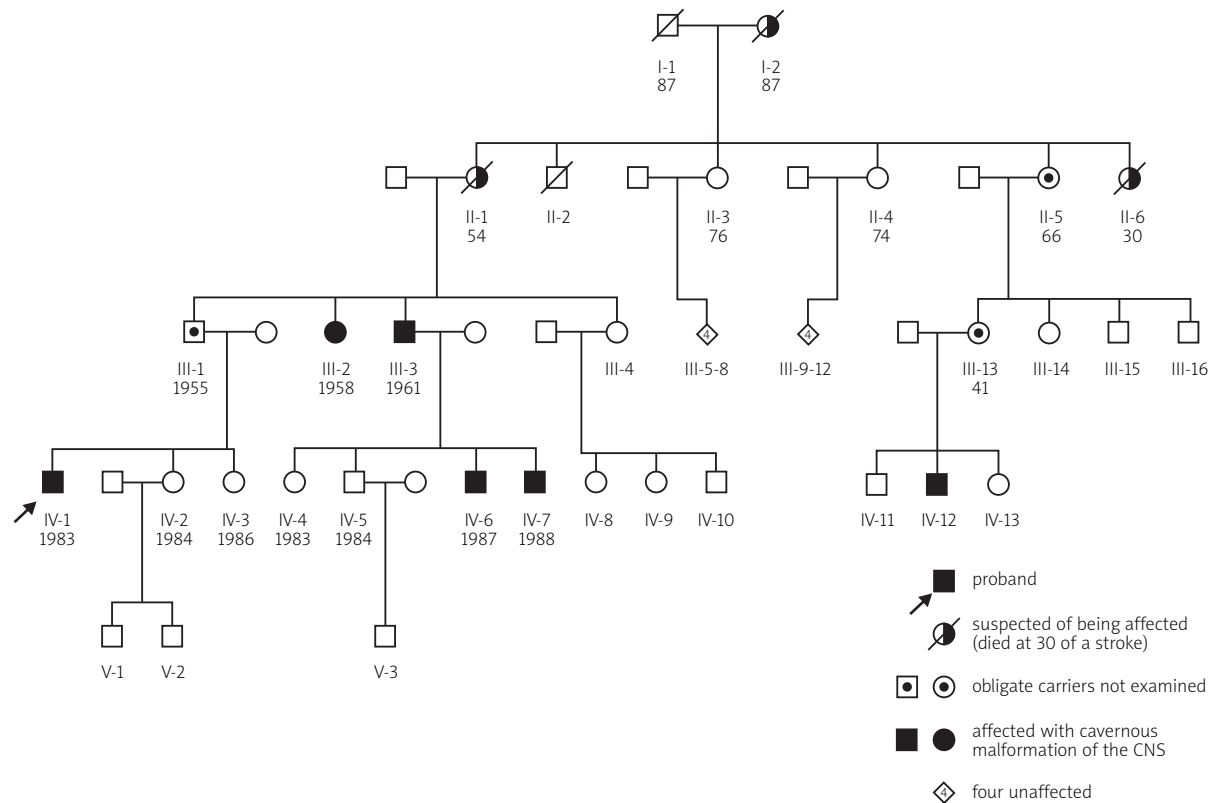

**Fig. 1.** Family pedigree with familial form of cavernous malformation.

**Case 1 (IV-1).** A 28-year-old man was admitted to the Department of Neurosurgery due to progressive weakness of the left upper and right lower extremity over the previous month. On admission, neurological examination revealed the loss of sensation on the right half of the face and hypoglossal nerve paresis, discrete pyramidal tract signs of the left upper and right lower limb, loss of superficial sensation in these limbs, and gait on a wide base. The MRI T2 sequences identified a mass in the medulla oblongata with radiological appearance of cavernous malformation (Fig. 2). The cerebral angiography excluded the presence of arteriovenous malformation. The patient underwent surgery, but in the early postoperative period he experienced a discrete vertical nystagmus and vertigo, which significantly decreased over the course of hospitalization. A small fragment of the resected specimens was obtained for histopathological examination and re-

vealed several gaping vascular spaces with collagenized walls, typical for cavernous malformation. The patient underwent genetic testing that documented mutation in the *CCM1* gene.

**Case 2 (IV-7).** A 22-year-old man, who presented with a first event of seizures, was admitted to the Department of Neurosurgery. At the age of 8, he underwent surgical resection of two cavernous malformations located in the right frontal lobe and right side of the pons (Figs. 3 B,C). At the age of 18, he experienced intracerebral haemorrhage in the right frontal lobe with extension into the ventricles, and was treated conservatively. On admission to our department, neurological examination revealed discrete left sided paresis and hypoplastic left extremities. The MRI of the brain revealed two lesions with characteristic appearance of cavernous malformations: one in the right frontal lobe close to the previously operated area, and the second



**Fig. 2.** MRI reveals a cavernous malformation in the brainstem. (A, B, C) T2-weighted MRI images show the lesion (white arrow) containing multiple small cystic spaces ("popcorn-like") with hypointense hemosiderin rim.



**Fig. 3.** MRI reveals multiple cavernous malformations. A, C) T1-weighted MRI images show "de novo" lesions. B) T1-weighted MRI image shows total removal of cavernous malformation located in pons.



“de novo” cavernous malformation in the right occipito-temporal region (Figs. 3 A,C). The electroencephalogram revealed that CCM in the frontal lobe was epileptogenic and only this lesion was removed surgically. In the postoperative period, there was no exacerbation of neurological deficits.

Histopathological examination confirmed the diagnosis of cavernous malformation. The lesion consisted of closely apposed vessels of varying calibre and degree of hyalinization. Some parts were composed mainly of thin-walled vascular channels and enlarged spaces, lined by a single layer of endothelium without smooth muscle and elastin (Figs. 4A, B). However, numerous vessels exhibited extensive collagenization and hyalinization of the vascular walls. Small vessels or enlarged draining veins were also encountered. The lesion lacked intervening brain parenchyma. Secondary changes, including advanced thickening of the vascular

wall with fibrosis and calcification, luminal thrombosis (Fig. 4C) and haemorrhages were present. The reactive changes included inflammatory infiltrates that were composed of perivascular accumulation of lymphocytes and hemosiderin-laden macrophages. The surrounding tissue showed advanced reactive astrocytosis and fibrosis with numerous hemosiderin deposits and haematoidin crystals (Fig. 4D).

**Case 3 (IV-6).** A 23-year-old man underwent surgery twice due to brain cavernous malformation located in the deep structures of the right hemisphere. The first operation was performed at the age of 3. At the age of 12, MR imaging revealed a lesion with radiological appearance of CCM, not reported in previous MRI findings. The patient underwent a second operation for this new lesion.

**Case 4 (III-3).** A 51-year-old man who, despite the absence of symptoms, underwent imaging studies be-

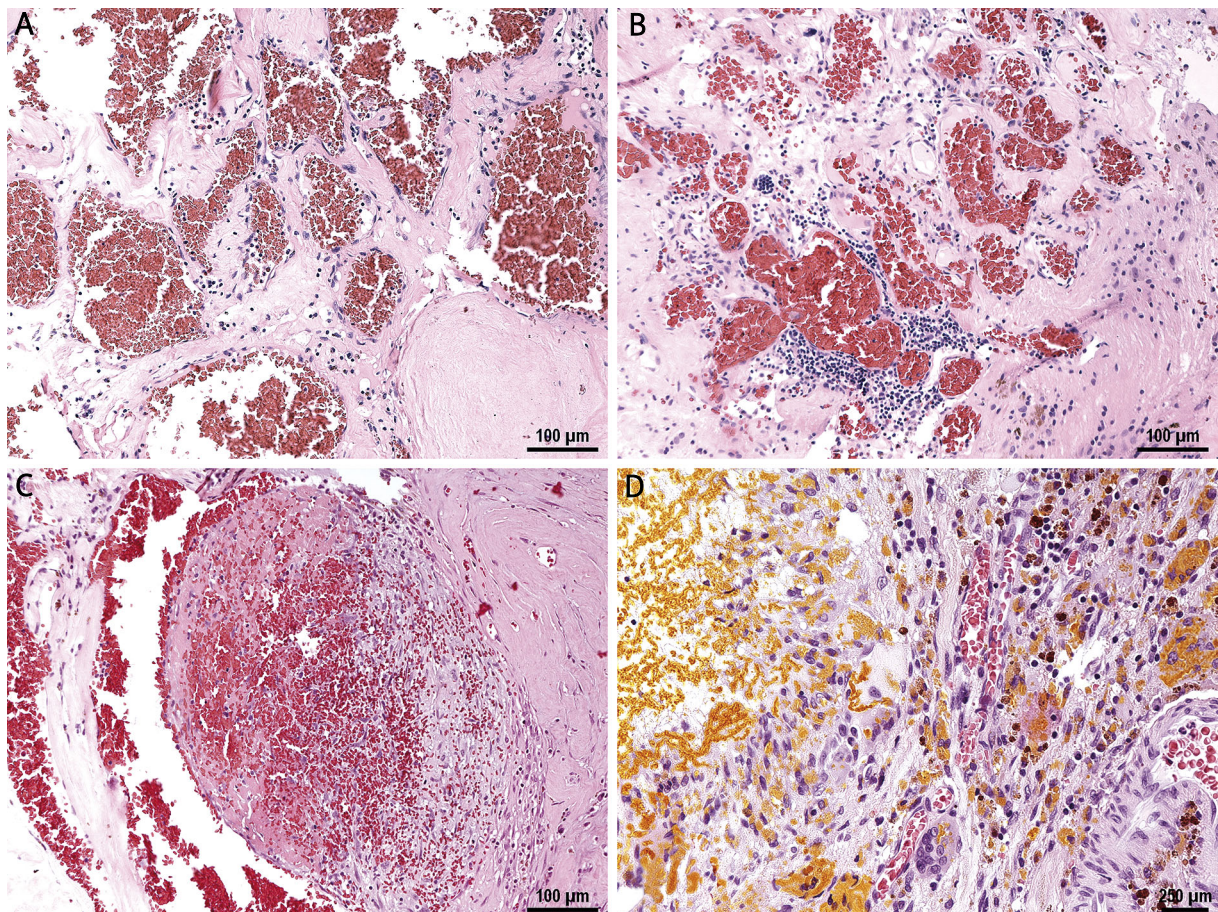

**Fig. 4.** Histopathology of cavernous malformation, H&E. **A, B)** Thin-walled vascular spaces of varying size, lined by a single layer of endothelium. **C)** Enlarged vessel with fibrosis and luminal thrombosis. **D)** Surrounding tissue with advanced hemosiderin and haematoidin deposits. Bars: A, B, D – 100 µm, C – 250 µm.

cause of his family history documenting the presence of cavernous malformation in his two sons. MRI showed three lesions with radiological features of cavernous malformations. To date, he is still asymptomatic.

**Case 5 (III-2).** A 53-year-old woman was treated surgically due to cerebral cavernous malformation at the age of 18 in another department and more data are not available.

**Case 6 (IV-12).** A 21-year-old man, who was twice treated surgically due to cerebral cavernous malformations. At the age of 11, the patient underwent surgical excision of CCM in the right frontal lobe. At the follow-up, at the age of 15, the MR imaging study revealed a new lesion in the cerebellar vermis. Despite the absence of symptoms, surgery of this lesion was performed. After surgery, neurological examination revealed double vision and vertigo.

**Case 7 (III-13).** A 41-year-old woman with a family history of CCM and whose son was operated on because of cavernous malformation. She is currently without neurological symptoms but it turns out that she is an obligatory *CCM2* gene carrier. Neuroradiological studies were not performed.

**Case 8 (III-1).** A 56-year-old man currently asymptomatic, whose son was treated due to cavernous malformation, turns out to be an obligatory *CCM2* gene carrier. An imaging study was not performed.

## Discussion

### Family occurrence and inheritance

Cavernous malformations (cavernous angiomas, cavernous haemangiomas, cavernomas) are vascular malformations of the central nervous system that may occur as sporadic or inherited autosomal-dominant forms due to mutation in one of three genes, in which mutations are known to cause familial CCM [11]. The incidence of CCMs is related to the geographical region [18]. It has been documented that they occur more frequently in those of Mexican-American ethnicity [18]. The gene penetration within one family varies, which is also supported by our study. Symptoms in the proband (Case 1) occurred at the age of 28 when he noticed progressive left upper and right lower extremity weakness. In one of his cousins, the diagnosis was made at the age of 3, when the first seizure appeared. The 56-year-old father of the proband, who is an obligatory gene carrier, is asymptomatic until now.

## Incidence

According to the literature, the age of adult presentation is in the 4<sup>th</sup> and 5<sup>th</sup> decade of life, and in children two peaks can be observed, between 0-2 and 13-16 years [18,10]. In our family, the age of first symptoms occurred from 3 to 28 years, an average of 13.6 years. All symptomatic patients presented with symptoms before 30 years of age. In one case, a new lesion was found at the age of 15 and the lesions in other patients were found between 2 and 13 years of age. The presentation of cavernous malformations before the age of 30 predominantly occurs in men. The study of our family confirmed this gender predominance (6 men and 2 woman). However, symptomatic cavernous malformations have been described with equal frequency in women and men [7,19].

## Location and clinical manifestation

In our family, cavernous malformations were located infratentorially (medulla oblongata, cerebellar vermis and pons) in three patients (42%) and supratentorially (frontal and parieto-occipital lobe) in four cases (58%). The infratentorial localization of CCMs was more common when compared to data based on a large group of patients (1055) reported by Gross *et al.* with 23% of CCMs in infratentorial, 76% in supratentorial and 9% in both localizations [7]. The natural history of CCMs depends on their localization [13]. In our family, one patient with a supratentorial lesion presented with progressive paresis and the patients with infratentorial localization of the cavernoma presented with focal neurological deficits. Headaches are present in 30-50% of patients with CCMs [4]. Before the introduction of MRI, all patients with diagnosed cavernous malformation were symptomatic as indicated by Voigt and Yasargil [16], while asymptomatic cavernous malformation was detected mainly at autopsy [17]. Currently, CCMs are also diagnosed without clinical presentation [4]. In our family, two asymptomatic patients were diagnosed with magnetic resonance imaging.

## Multiple and “de novo” lesions

In familial cases of inherited cavernous malformation, multiple and “de novo” changes are more frequently present. Multiple lesions occur in approximately 50% of patients with a familial form of CCMs, and in 12-20% of sporadic cases [8,18]. Four members of the

family presented here were found to demonstrate multiple lesions on MR imaging studies (50%). The incidence of “de novo” lesions in the sporadic form accounts for 4.1%, and in the inherited form for about 30% [18]. In our studies, three patients (3 out of 5, i.e. 60% of those with complete medical records available) have a new single lesion, not previously observed, found in subsequent imaging studies.

### Genetic changes

The proband underwent molecular genetic testing and *CCM2* variation was found. Genetically, cerebral cavernous malformation (CCM) (OMIM 116860) is a heterogeneous condition with three genes involved: *CCM1* caused by mutation in the *KRIT1* gene on chromosome 7q21-q22; *CCM2* caused by mutation in the malcavernin gene (*MGC 4607*) on chromosome 7p13-p15; and *CCM3* caused by mutation in the *PDCD10* gene on chromosome 3q25.2-q27. Protein products of those genes (CCM proteins) probably regulate, in a complex way, endothelial cell morphogenesis and stability of blood vessels [6]. In pathogenesis of CCM, the Knudson double-hit mechanism seems to be involved [2]. Proportions of families affected with *CCM1*, *CCM2* and *CCM3* have been assessed as 40%, 20% and 40% respectively [5]. According to Toldo *et al.* (2009) mutations in *CCM1* account for approximately 70% of the familial CCM cases [15]. Up to 2010, more than 150 mutations were identified in all three above named genes (D’Angelo *et al.*, 2010). Molecular analysis performed in the presented family made it possible to identify a mutation in exon 15 of the *CCM1* gene (*KRIT1*), c.1595 del TT. The same mutation was found previously in only one family reported by Toldo *et al.* (2009).

### Management

According to recent literature indications, incidentally discovered CCMs should be managed conservatively and followed by periodic MR imaging. Symptomatic lesions responsible for seizure, progressive neurological deficit, the first clinically significant haemorrhage in non-eloquent areas and a second haemorrhage in eloquent areas should be considered for surgical removal [4]. In our department, asymptomatic patients are treated conservatively irrespective of the CCM location. In some centres, as reported by Ablá [1], mildly symptomatic patients are operated on for cavernous malformation even when located in the brainstem. Molecular genetic testing should be performed on all

family members when the family has a positive history of CCM presence.

### Conclusions

Both clinical and family history is necessary in the diagnosis of cavernous malformation, including epilepsy events and focal neurological deficit in family members. This is particularly important in patients who exhibit multiple malformative changes, or “de novo” lesions in control MRI studies. These data are useful in the diagnosis of inherited CCM and make it possible to offer all members of the family proper neurological and genetic care.

### References

1. Ablá AA, Turner JD, Mitha AP, Lekovic G, Spetzler RF. Surgical approaches to brainstem cavernous malformations. *Neurosurg Focus* 2010; 29(3): E8.
2. Akers AL, Johnson E, Steinberg GK, Zabramski JM, Marchuk D. Biallelic somatic and germline mutations in cerebral cavernous malformations (CCMs): evidence for two-hit mechanism of CCM pathogenesis. *Hum Molec Genet* 2009; 18: 919-930.
3. Campbell PG, Jabbour P, Yadla S, Awad IA. Emerging clinical imaging techniques for cerebral cavernous malformations: a systematic review. *Neurosurg Focus* 2010; 29: 3E6.
4. Chalouhi N, Dumont AS, Randazzo C, Tjoumakaris S, Gonzalez LF, Rosenwasser R, Jabbour P. Management of incidentally discovered intracranial vascular abnormalities. *Neurosurg Focus* 2011; 31: 1-12.
5. Dubovsky J, Zabramski JM, Kurth J, Spetzler RF, Rich SS, Orr HT, Weber JL. A gene responsible for cavernous malformations of the brain maps to chromosome 7q. *Hum Mol Genet* 1995; 4: 453-458.
6. Faurobert E, Albiger-Rizo C. Recent insights into cerebral cavernous malformations: a complex jigsaw puzzle under construction. *FEBS J* 2010; 277: 1084-1096.
7. Gross B, Lin N, Du R, Day A. The natural history of intracranial cavernous malformations. *Neurosurg Focus* 2010; E144.
8. Kroh H, Andrychowski J. Multiple cerebral cavernous angiomas. Case report. *Folia Neuropathol* 1995; 33: 51-54.
9. Moriarity JL, Wetzel M, Clatterbuck RE, Javedan S, Sheppard JM, Hoenig-Rigamonti K, Crone NE, Breiter SN, Lee RR, Rigamonti D. The natural history of cavernous malformations: A prospective study of 68 Patients. *Neurosurgery* 1999; 44: 1166-1171.
10. Mottollese C, Hermier M, Stan H, Jouvét A, Saint-Pierre G, Froment JC, Bret P, Lapras C. Central nervous system cavernomas in the Pediatric age group. *Neurosurg Rev* 2001; 24: 55-73.
11. Revencu N, Vikkula M. Cerebral cavernous malformation: new molecular and clinical insights. *J Med Genet* 2006; 43: 716-721.
12. Rigamonti D, Hadley MN, Drayer BP, Johnson PC, Hoenig-Rigamonti K, Knight JT, Spetzler RF. Cerebral cavernous malformations. Incidence and familial occurrence. *N Engl J Med* 1988; 319: 343-347.
13. Robinson JR, Awad IA, Little JR. Natural history of the cavernous angioma. *J Neurosurgery* 1991; 75: 709-714.

14. Simard JM, Garcia-Bengochea F, Ballinger WE Jr, Mickle JP, Quisling RG. Cavernous angioma: a review of 126 collected and 12 new clinical cases. *Neurosurgery* 1986; 18: 162-172.
15. Toldo I, Dringo P, Mammi I, Marini V, Carollo C. Vertebral and spinal cavernous angiomas associated with familial cerebral cavernous malformation. *Surg Neurol* 2009; 71: 167-171.
16. Voight K, Yasargil MG. Cerebral cavernous haemangiomas or cavernomas. Incidence, pathology, localization, diagnosis, clinical features and treatment. Review of the literature and report of an unusual case. *Neurochirurgia (Stuttg)* 1976; 19: 59-68.
17. Wakai S, Ueda Y, Inoh S, Nagai M. Angiographically occult angiomas: a report of thirteen cases with analysis of the cases documented in the literature. *Neurosurgery* 1985; 17: 549-556.
18. Washington C, McCoy K, Zipfel G. Update on the natural history of cavernous malformations and factors Predicting aggressive clinical presentation. *Neurosurg Focus* 2010; E7.
19. Zabramski JM, Wascher TM, Spetzler RF, Johnson B, Golfinos J, Drayer BP, Brown B, Rigamonti D, Brown G. The natural history of cavernous malformations: results of an ongoing study. *J Neurosurg* 1994; 80: 422-432.